

Performance Hoist



PH75TL

Our extra-wide lift has adjustable runways, made to accommodate a variety of trailer axel widths.

Specifications:

Lifting Capacity	7,500 lbs.
Power requirements	110v
Top of runway on maximum lock height	84 3/8"
Clearance under runway on top lock	79 5/16
Thickness of runway	5"
Length of runway	196"
Length of drive-on approach ramp	37"
Overall length	202 5/16"
Height of columns (overall height)	99 7/8 "
Runway width	19"
Width between runways	49 1/2" - 69 1/2" (Adjustable)
Measurement to outside of both runways	88 1/2" – 107 1/2" (Adjustable)
Clearance between columns	124 3/4"
Overall width	134 9/16"



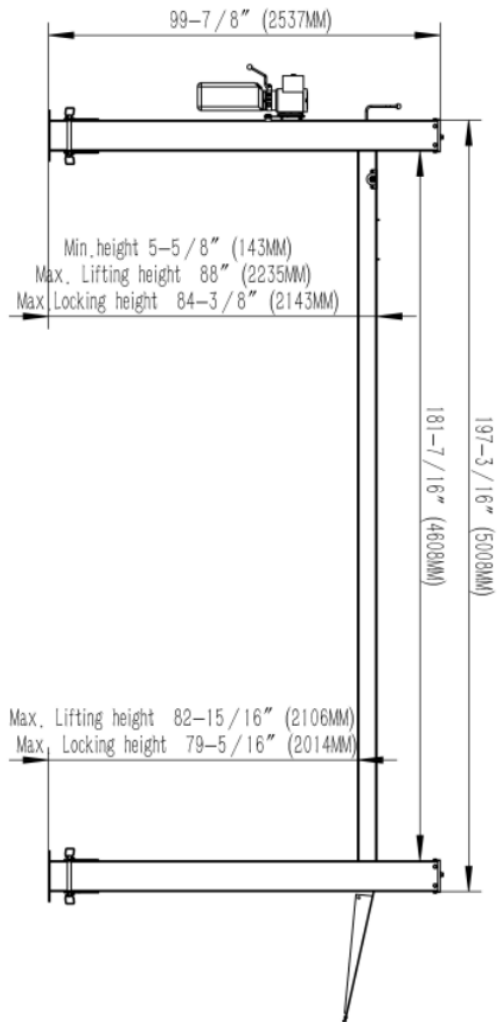
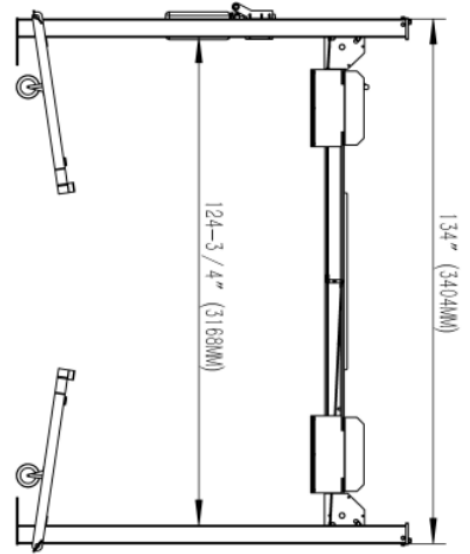
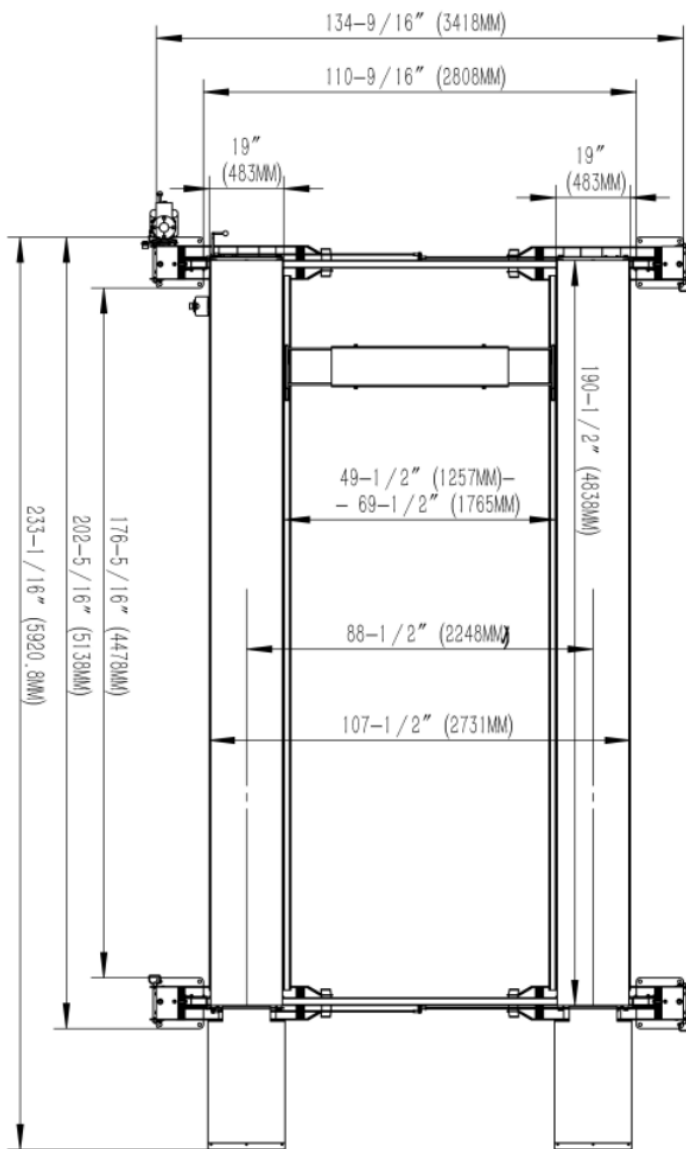



Sliding tray to hold trailer jack leg, expands according to the placement of the runways



Hydraulic cylinder under the runway has explosion-proof valve

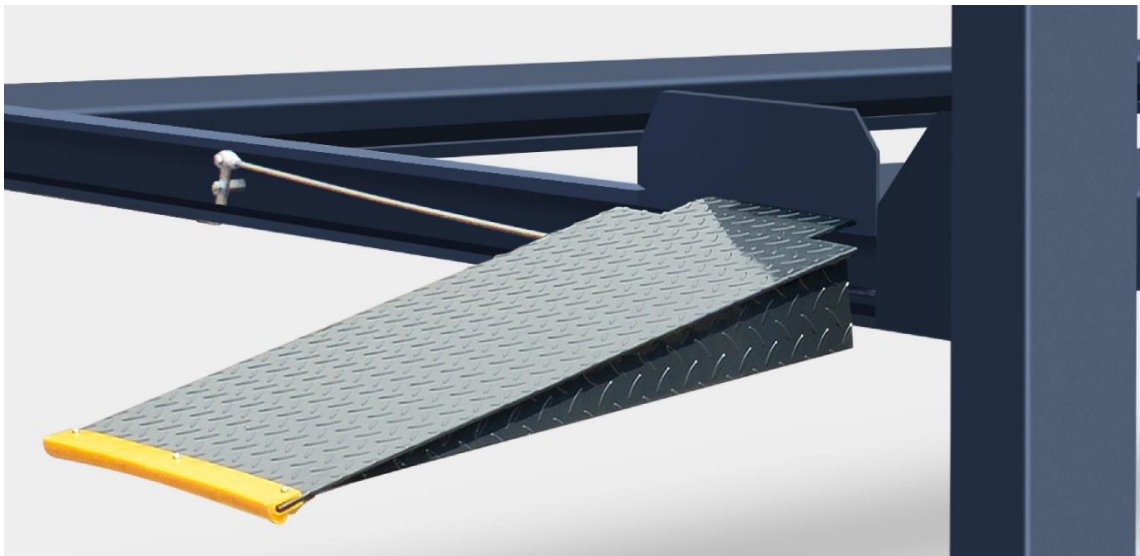

Drive-on ramps have protection on edge to prevent scratching floors

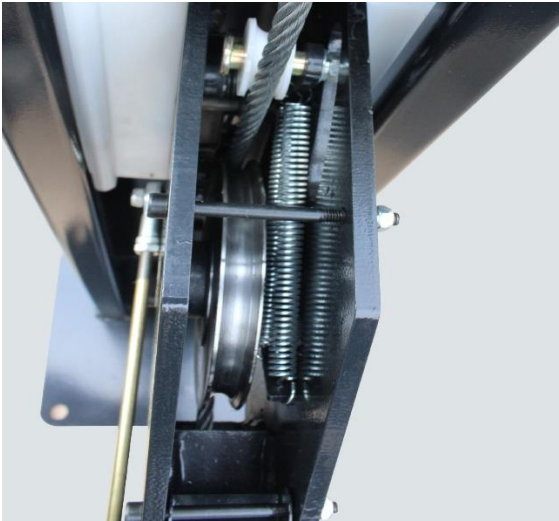

Safety locks



Removeable Wheel castors



Heavy-duty release mechanism and runway stoppers



Welded on steel doubling on the underside of the ramps for extra strength